

BC Cryogenic Globe Valve

| NSTE Corporation Limited

Long-stem for Cryogenic Liquid and Gas

NS_100B

“BC Cryogenic Long-stem Globe Valve” is designed to provide positive shut-off of cryogenic liquid systems.

This valve is used extensively in bulk storage tanks, portable liquid cylinders and pipelines for LO₂, LN₂ and LAr. Unique design and manufacturing technology give much better price and more reliability.

Product Specifications

Design pressure: 3.0MPa
 Design temperature: -196°C~75°C
 Kind of fluid: LN₂, LO₂, LAr, LCO₂, LNG, LC₂H₄
 Hydrostatic test pressure: 4.5MPa
 Pneumatic test pressure: 3.3MPa

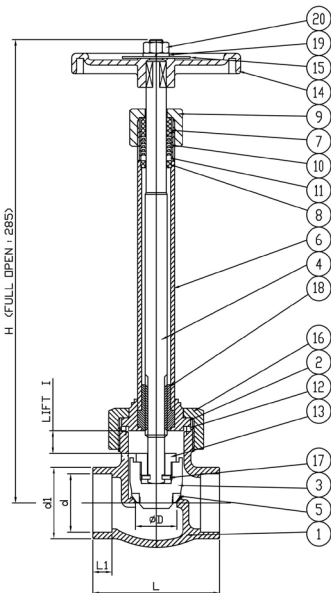

Service characteristics

No	Name	Material	No	Name	Material
1	Body	BC 7	13	Disc Lock Nut	C3604
2	Bonnet	C3604	14	Hand Wheel	ALDC8
3	Valve Disc	C3604	15	Name Plate	A1100P
4	Stem	STS 304	16	Union Nut	C3604
5	Disc Seat	PCTFE	17	Snap Ring	STS 304
6	Extended Pipe	STS 304 TP	18	Stud Nut	C3604
7	Gland Ring	C3604	19	Spring Washer	STS 304
8	Packing Ring	STS 304	20	Hex' Nut	STS 304
9	Grand Nut	C3604			
10	Packing	PTFE			
11	Packing Adapter	PTFE			
12	Gasket	V#7020			

* No maintenance is required other than replacement of seat assembly if any problems happen.

NS100b Ordering information

Model No.	SIZE	ØD	d	d1	L	L1	I	W	H	Cv
NS100b-10A-SW	3/8" (10A)	12	17.5	26	56	8	8	80	200	2.0
NS100b-15A-SW	1/2" (15A)	15	21.9	30	62	9	10	80	245	2.9
NS100b-20A-SW	3/4" (20A)	20	27.4	36.8	70	11	12	100	270	6.1
NS100b-25A-SW	1" (25A)	25	34.2	44	76	12	13.5	100	285	9.3
NS100b-32A-SW	1-1/4" (32A)	32	42.9	52	90	13	16	100	350	14.0
NS100b-40A-SW	1 1/2" (40A)	40	48.8	62	110	14	22	140	430	25.0
NS100b-50A-SW	2" (50A)	50	61.0	74	130	15	25	140	460	38.0



<http://www.nstecontrol.com> E-mail: jyc9400@naver.com
 320, Jedo-ro 1041beon-gil, Gangseo-gu, Busan
 Tel. +82-51-941-3131 Fax +82-51-941-3132