

Bronze Diverter Valve

| NSTE Corporation Limited

For Cryogenic Safeties

“Bronze Diverter Valve” is designed to divert the safety and rupture disc in cryogenic liquid systems. This valve is used extensively in safety system for bulk storage tanks, portable liquid cylinders and pipelines for LO_2 , LN_2 , LAr and LNG.

NS_400B

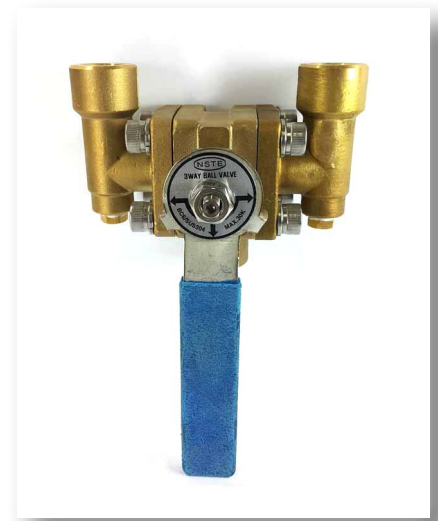

Product Specifications

Design pressure: 3.0MPa
 Design temperature: $-196^{\circ}C \sim 75^{\circ}C$
 Kind of fluid: LN_2 , LO_2 , LAr , LCO_2 , LNG
 Hydrostatic test pressure: 4.5MPa
 Pneumatic test pressure: 3.3MPa

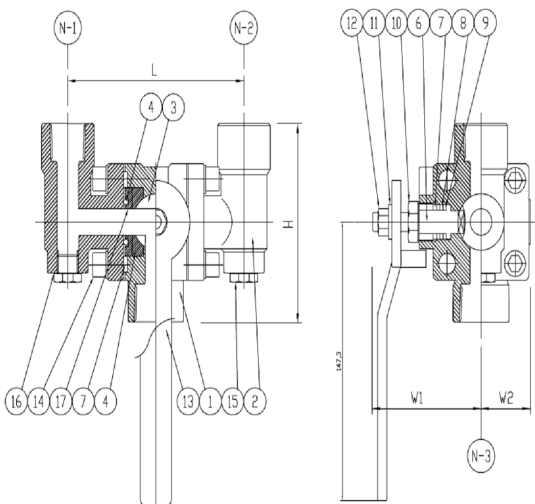

Service characteristics

No	Name	Material	No	Name	Material
1	Body	C3771	10	Stem Bush	SUS 304
2	Cap	C3771	11	Spring Washer	SUS 304
3	Ball	SUS 304	12	Nut	SUS 304
4	Ball Seat	R-PTFE	13	Lever	SUS304
5	O-ring	VITON	14	Bolt	SUS 304
6	Stem	SUS 304	15	Plug Bolt	C3771BD
7	Gland Packing	R-PTFE	16	Gasket	R-PTFE
8	Gland Ring	SUS 304	17	Liner	R-PTFE
9	Bearing	R-PTFE			

* No maintenance is required other than replacement of seat assembly if any problems happen.

NS400b Ordering information

Model No.	SIZE	L	H	T	W1	W2	Nozzle size	N-1	N-2	NN-3	Φ
NS400b-15A	1/2" (15A)	114	106	155	70	30			1/2" NPT	1/2" NPT	3/4" PT
NS400b-25A	1" (25A)	136	126	155	80	40		1" NPT	1" NPT	1" NPT	20mm
NS400b-40A	1 1/2" (40A)	204	165	183	109	54		1 1/2" NPT	1 1/2" NPT	1 1/2" NPT	31mm



<http://www.nstecontrol.com> E-mail: jyc9400@naver.com
 320, Jedo-ro 1041beon-gil, Gangseo-gu, Busan
 Tel. +82-51-941-3131 Fax +82-51-941-3132